

## SciCloneX™ Separator Installation Manual



## Installation Procedures

The SciCloneX™ Hydrodynamic Separator is designed to remove high levels of trash, debris, sediments and hydrocarbons. Its simple design allows for quick and easy installation. The system is housed in a standard precast manhole structure and can be installed at various depths to meet site-specific conditions. Various size units are available from 4' to 12' in diameter. In some areas, 13' and 14' diameter units may be available.

### ***Delivery & Unloading / Lifting***

- Contech shall deliver the unit(s) to the site in coordination with the Contractor.
- The Contractor may be required to provide spreader bars and chains/cables to safely and securely lift the base section, risers, and top section along with suitable lifting hooks, knuckles, shackles and eyebolts.
- Please see project specific drawings for weights and lifting details. Contact Contech for additional lifting details. Internal components are pre-installed prior to delivery.

### ***Inspection***

- Inspection of the SciCloneX and all parts contained in or shipped outside of the unit shall be inspected at time of delivery by the site Engineer/Inspector and the Contractor. Any nonconformance to approved drawings or damage to any part of the system shall be documented on the Contech shipping ticket.
- Damage to the unit during and after unloading shall be corrected at the expense of the Contractor. Any necessary repairs to the SciCloneX unit shall be made to the acceptance of the Engineer/Inspector.

### ***Site Preparation***

- The Contractor is responsible for providing adequate and complete vault protection when the SciCloneX unit is installed prior to final site stabilization (full landscaping, grass cover, final paving, and street sweeping completed).
- The Contractor shall adhere to all jurisdictional and/or OSHA safety rules in providing temporary shoring of the excavation.
- The Contractor or Owner is responsible for appropriately barricading the SciCloneX unit from traffic (in accordance with local codes).



## Installation

- Each SciCloneX unit shall be constructed based on the locations and elevations according to the sizes shown on the approved drawings. Any modifications to the elevation or location shall be at the direction of and approved by the Engineer.
- The SciCloneX unit shall be placed on level compacted sub-grade with a minimum 6-inch gravel base. Compact undisturbed sub-grade materials to be per Geotechnical/Soils report. Unsuitable material below sub-grade shall be replaced to site engineer's approval. Place granular sub-base and compact to State and local standards as per the Engineers requirements.
- Once the base piece is set, the riser(s) and top section should be sealed onto the base section before backfilling, using a non-shrink grout, butyl rubber or similar waterproof seal.
- Pipe connections shall be aligned and sealed to meet the approved drawings with modifications necessary to meet site conditions and local regulations. The correct connection (inlet/outlet) will be marked on the Contech Vault unit. NOTE: The inlet and outlet pipe cannot protrude past the structures I.D. wall as it will interfere with the internal components.
- Once the SciCloneX unit is set, it should be protected from construction runoff entering it. Contractor will be responsible for cleaning if unit is contaminated by such construction runoff and associated pollutants and damaged (i.e. concrete wash water).
- Backfilling should be performed in a careful manner, bringing the appropriate fill material up in 6-inch lifts on all sides. Precast sections shall be set in a manner that will result in a watertight joint. In all instances, installation of the SciCloneX unit shall conform to ASTM specification C891 "Standard Practice for Installation of Underground Precast Utility Structures" unless specified otherwise in contract documents.
- If applicable, it is the responsibility of the Contractor to provide curb and gutter and transition to the SciCloneX unit for proper stormwater flow into the system through the throat, pipe or grate opening. A standard drawing of the throat and gutter detail is available in the following section; however the plans and contract documents supersede all standard drawings. Several variations of the standard design are available. Effective bypass for an offline SciCloneX unit is essential for correct operation (i.e. bypass to an overflow at lower elevation).



## ***Pipe Connection Details***

- Pipe material selection should be indicated on the Site Plan. Connect the pipe using a Kor-N-Seal, Press Seal, Fernco, or other approved watertight boot connection. In the case of concrete pipes, grout the connection watertight with non-shrink grout.
- Inlet pipe(s) shall be stubbed in and connected to the precast manhole according to the Engineer's requirement or specifications. The Contractor is to grout all inlet pipes flush with the interior wall of the structure per plans and specifications.
- Outlet pipe shall be stubbed in and connected to the precast manhole according to the Engineer's requirement or specifications. The Contractor is to grout all inlet pipes flush with the interior wall of the structure per plans and specifications.
- For illustration a BAD example of a pipe installation is included below. The pipe is off-center, the pipe invert is not in the appropriate position, it is protruding beyond the inside wall, the grout is not clean and properly finished. This site was corrected by re-excavating and reconnecting the pipe properly.



*Example of a BAD pipe installation. Protruding past the internal wall of the structure, poor grouting, and wrong position.*



*Example of a GOOD pipe installation. Pipe flush with the internal wall of the structure, clean grouting, and proper position.*

- Once the pipes are connected, carefully backfill around them, compacting in "lifts" that will not deflect, disturb or damage them.

## *Illustrative Step-by-Step Installation Process*

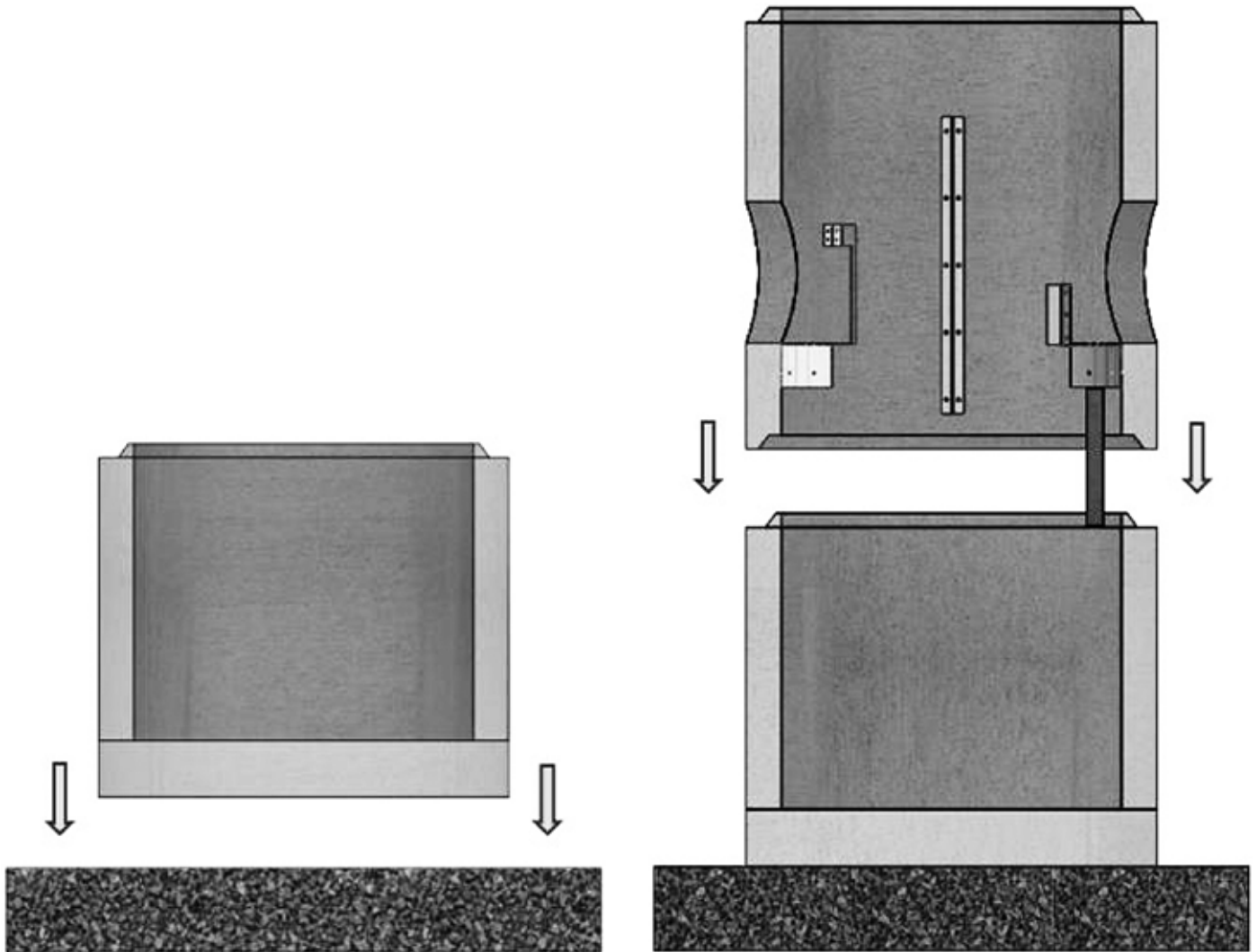

*1. Set the base section of the SciClone™ on solid sub-grade using appropriate rigging and lifting method. Add watertight seal (either mastec rope or rubber gasket). Verify the level and elevation of the base section before adding any additional precast riser sections.*

*2. Set riser section(s) on the base section. Set the riser section that contains the SciClone™ components. Verify the outlet pipe elevation using precise survey methods. Be sure to add watertight seal to each rise section. Pipe holes are contained within the riser section. Pipes can be connected at this time if access is required into the vault to grout from the inside.*

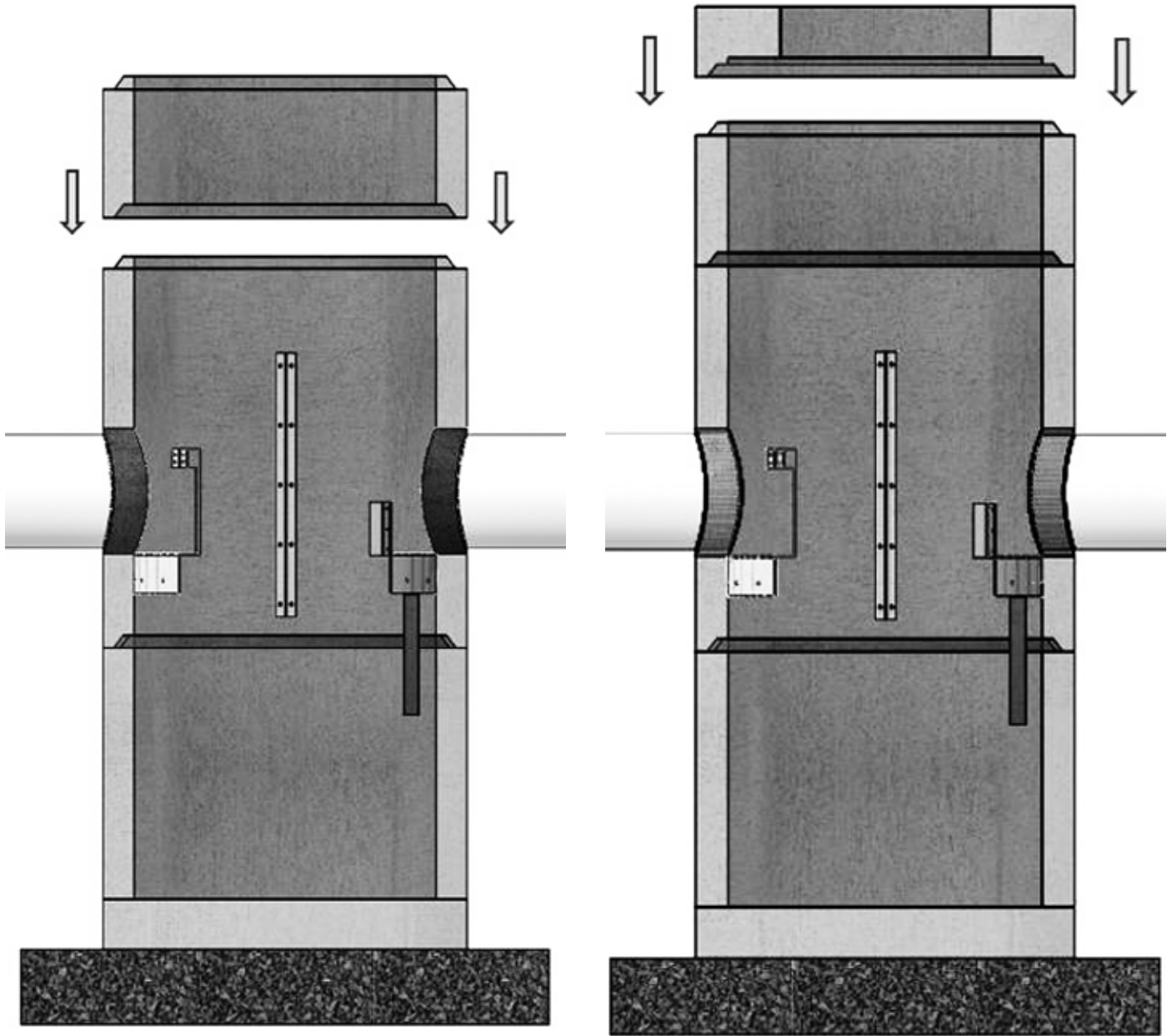

3. Set any additional riser sections, if required, using the same method as previous section. Be sure to add watertight seal to each rise section.

4. Set the top slab. Note the top slab's orientation. The manhole access opening(s) must be oriented over the inlet and outlet side of the oil/floatables skimmer per the drawings.



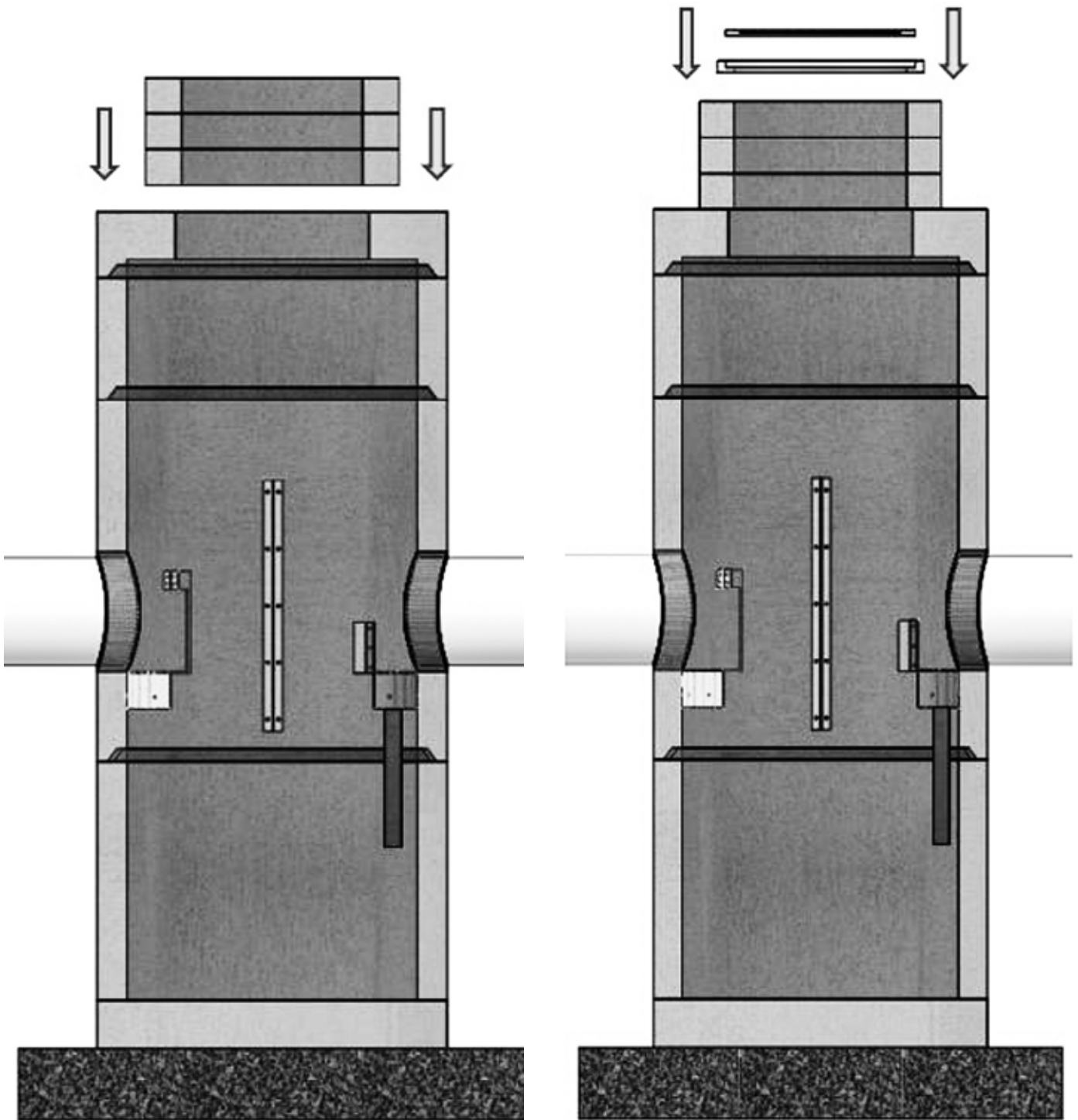

5. Set the base section of the SciCloneX™ on solid sub-grade using appropriate rigging and lifting method. Add watertight seal (either mastec rope or rubber gasket). Verify the level and elevation of the base section before adding any additional precast riser sections.

6. Set riser section(s) on the base section. Set the riser section that contains the SciCloneX™ components. Verify the outlet pipe elevation using precise survey methods. Be sure to add watertight seal to each rise section. Pipe holes are contained within the riser section. Pipes can be connected at this time if access is required into the vault to grout from the inside.

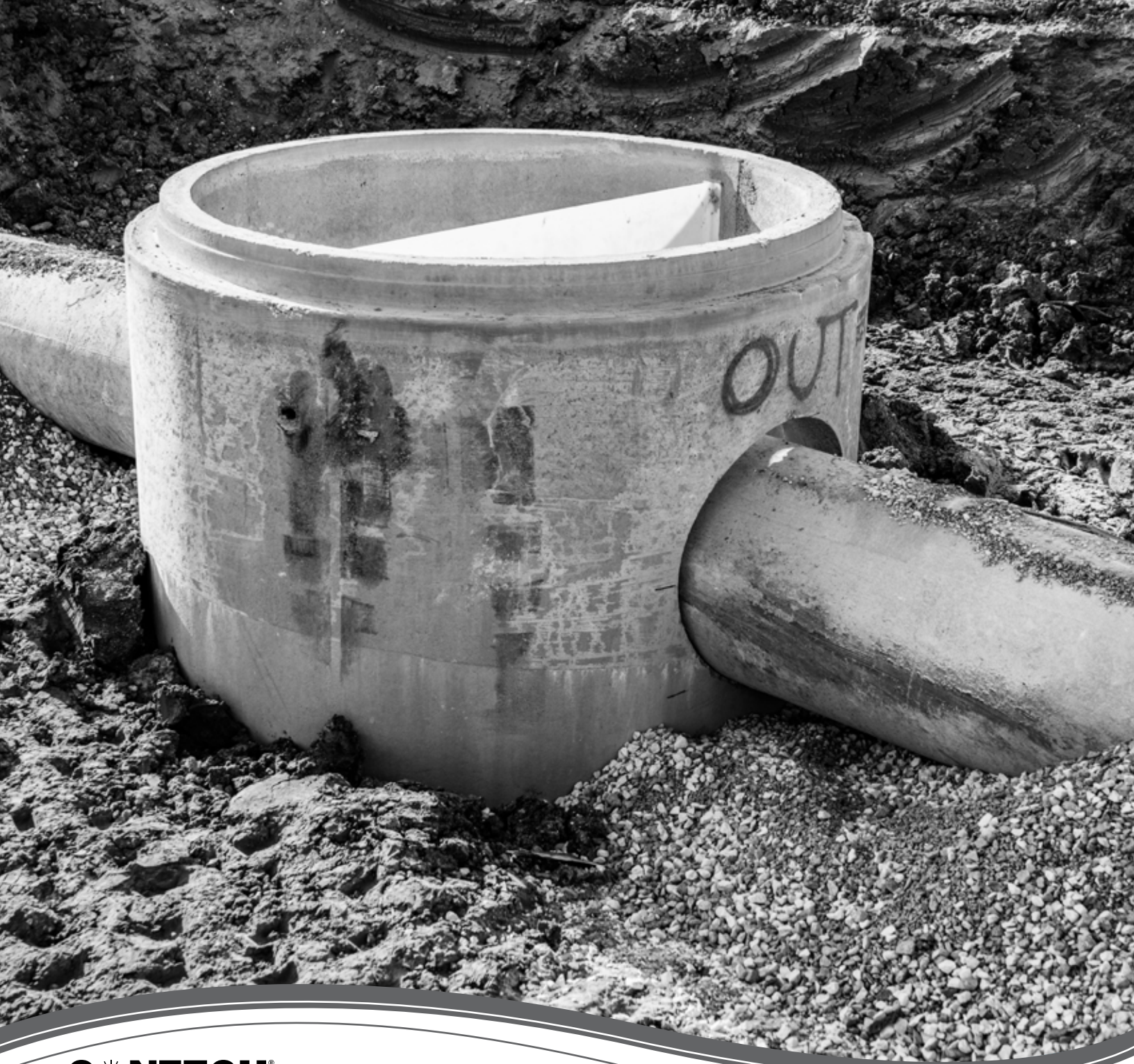

## **CONTECH**<sup>®</sup> ENGINEERED SOLUTIONS

© 2022 CONTECH ENGINEERED SOLUTIONS LLC, A QUIKRETE COMPANY

800-338-1122

[WWW.CONTECHES.COM](http://WWW.CONTECHES.COM)

ALL RIGHTS RESERVED. PRINTED IN THE USA.

CONTECH ENGINEERED SOLUTIONS LLC PROVIDES SITE SOLUTIONS FOR THE CIVIL ENGINEERING INDUSTRY. CONTECH'S PORTFOLIO INCLUDES BRIDGES, DRAINAGE, SANITARY SEWER, STORMWATER AND EARTH STABILIZATION PRODUCTS. FOR INFORMATION ON OTHER CONTECH DIVISION OFFERINGS, VISIT [WWW.CONTECHES.COM](http://WWW.CONTECHES.COM) OR CALL 800-338-1122.

NOTHING IN THIS CATALOG SHOULD BE CONSTRUED AS A WARRANTY. APPLICATIONS SUGGESTED HEREIN ARE DESCRIBED ONLY TO HELP READERS MAKE THEIR OWN EVALUATIONS AND DECISIONS, AND ARE NEITHER GUARANTEES NOR WARRANTIES OF SUITABILITY FOR ANY APPLICATION. CONTECH MAKES NO WARRANTY WHATSOEVER, EXPRESS OR IMPLIED, RELATED TO THE APPLICATIONS, MATERIALS, COATINGS, OR PRODUCTS DISCUSSED HEREIN. ALL IMPLIED WARRANTIES OF MERCHANTABILITY AND ALL IMPLIED WARRANTIES OF FITNESS FOR ANY PARTICULAR PURPOSE ARE DISCLAIMED BY CONTECH. SEE CONTECH'S CONDITIONS OF SALE (AVAILABLE AT [WWW.CONTECHES.COM/COS](http://WWW.CONTECHES.COM/COS)) FOR MORE INFORMATION.

### **SUPPORT**

DRAWINGS AND SPECIFICATIONS ARE AVAILABLE AT [WWW.CONTECHES.COM](http://WWW.CONTECHES.COM)

SciCloneX™ Separator Installation Manual 08/22