



CONTECH[®]
ENGINEERED SOLUTIONS
A QUIKRETE[®] COMPANY



Contech Slotted Drain™

CONTECH[®]
PIPE SOLUTIONS

Contech Slotted Drain™

Efficiently Remove Surface Water

Contech Slotted Drain is a practical, aesthetically pleasing inlet for the efficient removal of surface water on streets and highways. It also is widely used in parking lots and other similar locations, where it removes sheet flow without complex multiple grades or water channeling devices like asphalt dikes, berms and curbs.

Slotted Drain is fabricated from Contech Corrugated Steel Pipe. The pipe is cut along a longitudinal axis, and a trapezoidal or straight-sided grate with reinforcing spacer plates is welded in place to form a 1 3/4-inch-wide slot opening. The slot collects runoff and channels it to the pipe below, from which it flows to the appropriate outlet.

Slotted Drain is fabricated at plants throughout the United States, allowing fast delivery no matter where your project is located.

Contech Slotted Drain has a variety of applications for removal of surface water

- Curb inlets
- Inlet system across driveway cuts
- Shoulder drains along median barriers
- Pedestrian thoroughfares, malls and bicycle paths
- Replacements for curbs and berms where those obstacles are undesirable for safety reasons
- Ground-level floors with drainage requirements
- Parking lots or other continuous paved surfaces
- Sidelines of playing fields in stadiums
- Airport aprons, taxiways, hangars, and deicing areas
- Railroad intermodal facilities with heavy wheel loads

The trapezoidal design of the slot plus slanted spacer plates improve the hydraulic efficiency of Contech Slotted Drain and provide for easier maintenance.

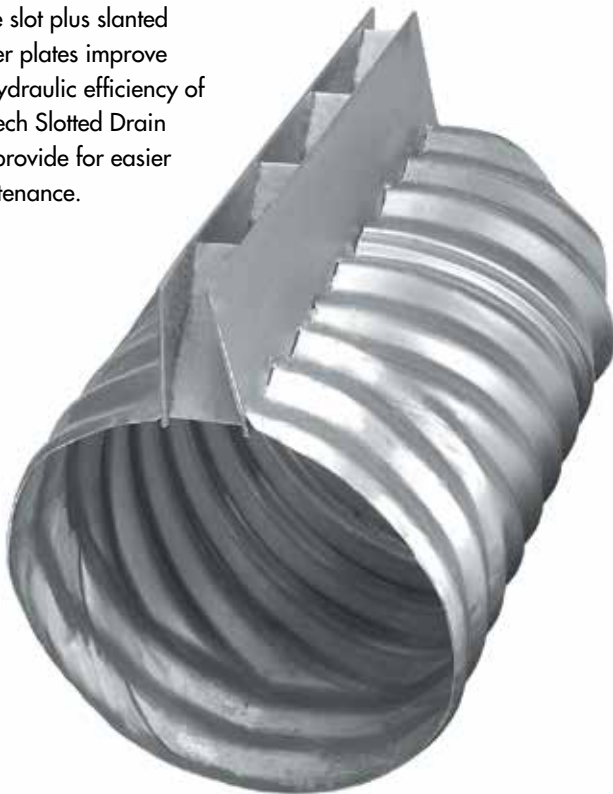

Parallel side grate is typically available and is used in variable-height grate applications. For variable-height grate information, see Pages 4 and 9.



Contech Slotted Drain Is Proven Superior To Other Drain Systems

Long, successful history

Contech Slotted Drain has been used at countless locations throughout the United States for more than 40 years... simply because it is the most effective solution to water removal problems.

Improved drainage efficiency

The grate on a standard 20-foot length of Slotted Drain will intercept up to 50% more runoff than most standard 2' x 2' grate inlets.* With solid cross plate spacers tipped at 30°, runoff is directed into the open slot for more efficient interception. (The hydraulic information on Page 7 will help determine the lengths of Slotted Drain needed to meet your hydraulic requirements.)

Structurally sound

Contech Slotted Drain is constructed of thick grate and thick spacer plates to resist deformation under heavy traffic loads and thermal expansion. The design has been tested using truck loading parallel and perpendicular to the slot.

The grate height of six inches is the most widely used height for standard AASHTO H 20 loading.

Better safety

Because Slotted Drain can be installed so that it extends only two inches from the curb, hazardous dips and ponding in grade are eliminated. Slotted Drain also minimizes hazards to two-wheel vehicles.

Fewer debris problems

FHWA testing on straight-sided grate has shown its efficiency to resist clogging to range from 73% to 86%. Slotted Drain will retain its effectiveness even when a localized blockage occurs in one area. Under similar conditions, a conventional drain would be severely restricted. Debris is less likely to block Slotted Drain's trapezoidal grate. Anything large enough to fit through the top of the slot opening will fall harmlessly through to the bottom of the drain.

Easier to maintain

There are no hardware or heavy grates to remove, and there are no protrusions that can be damaged with snow plows. It is cleaned by flushing with water from hoses.

No unusual freezing

When freezing occurs, slotted drain will handle ice, snow and runoff equally as well as any conventional drainage system.

Easier to install

Field experience indicates that the installation of Slotted Drain is much easier than the installation of conventional catch basin systems.

*Source: Figure 15, Hydraulic Engineering Circular No. 12, U.S. Department of Transportation, March 1984. This document is available from the National Technical Information Service, Springfield, VA 22161.

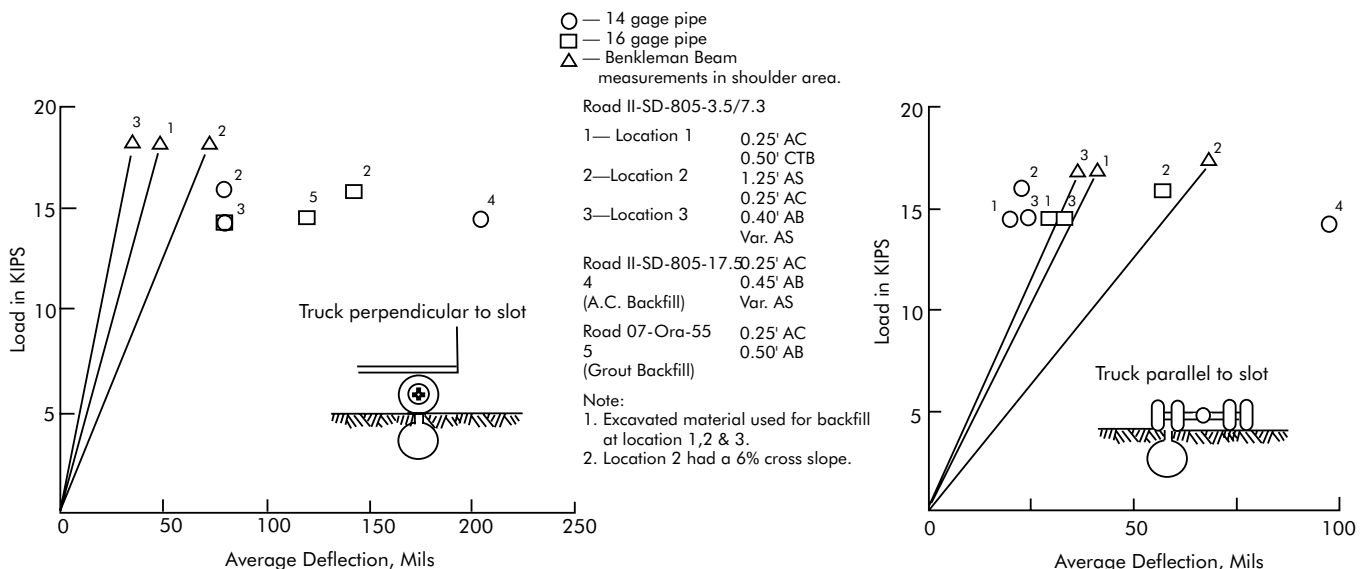

Product Details

Pipe

Slotted Drain made from Contech Corrugated Steel Pipe with HUGGER® Bands meets applicable portions of AASHTO Designation M36 and ASTM A760. Pipe is fabricated from galvanized steel for excellent durability, or from ALUMINIZED STEEL™ Type 2 when more corrosion resistance is required. Slotted Drain is available in 12-inch through 36-inch diameter HEL-COR® pipe and in 14-gage and 16-gage. Thirty and thirty-six inch diameter pipe is also available in 12-gage. Slotted Drain may also be provided in 18-inch through 36-inch diameter ULTRA FLO® pipe, and in 15-inch diameter with limited availability.

Grate

The Slotted Drain concept was developed in the early 1960s in California. From the beginning, a need for certain structural requirements was recognized in the grating design and in its attachment to the pipe wall. The Contech grating system and design is the result of many years of experience and is still widely used on State of California Department of Transportation projects.

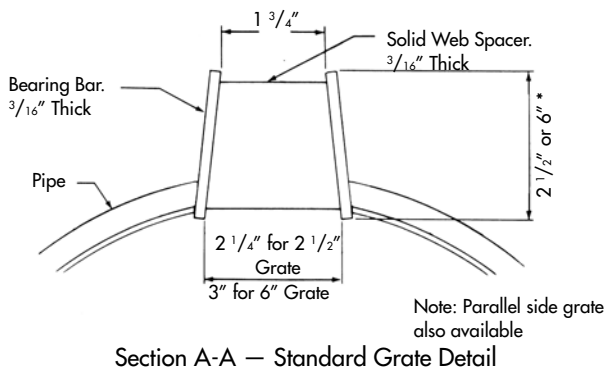
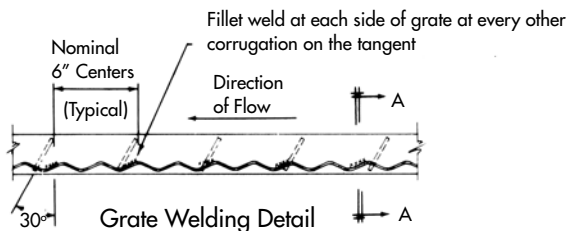
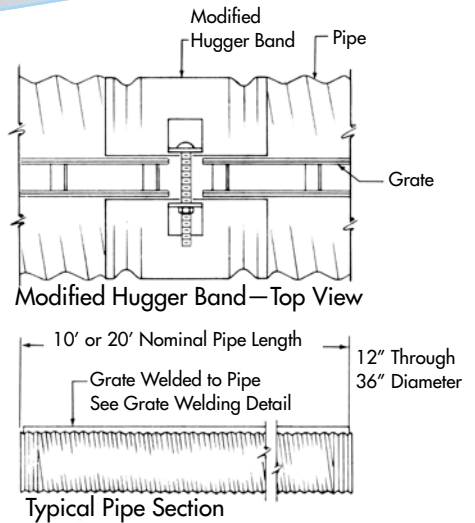

Joints and couplers

Standard 20-foot lengths of Slotted Drain normally are joined with a modified version of the HUGGER Band. Because the grate is extended to within one inch of the end of the pipe (to provide a fully continuous slot), the band is trimmed back to accommodate the grating at the joint. A single band bolt is provided for band tensioning.

An alternate jointing system is the use of closure plates. The closure plate jointing system helps align the grates and gives a more finished appearance as desired in some applications.

Heel guard

When Slotted Drain is installed in areas of heavy pedestrian traffic, expanded wire mesh can be specified for installation across the top of the drain opening. This helps prevent shoe heels from being caught in the open slot. Standard, galvanized, expanded metal mesh (1/2" x #13) is welded directly to the grating at the plant. As an alternative, paint wide, bright yellow warning stripes on the pavement adjacent to each side of the slot.

Fittings

A complete line of standard corrugated steel pipe fittings is available to simplify installation of slotted drain under many conditions: on a curve, through a change in elevation or through a change in pipe diameter.

Fittings include 90-degree tees, wyes and elbows with annular ends for attachment of the HUGGER Band; stubs, special junctions, angle/tee combinations and special end caps. These fittings do not have a grate.

Pipe diameters can be changed with a plate reducer.

Variable-height grate

Variable-height grates* (straight-sided grate only) can be supplied for installation on flat grades. Generally, the grade built into variable-height grates is a maximum of 1%. Ask your Contech Sales Engineer.

Tolerances (20-foot length)

The design engineer should be able to work with the manufacturing tolerances of vertical bow $\pm 3/8$ inch, horizontal bow $\pm 5/8$ inch and twist $\pm 1/2$ inch on a 6-inch grate. On special requirements, the engineer should call the local Contech Sales Engineer.

*Heights up to 31 inches are available in special straight-sided grates. Call your Contech Sales Engineer for details.

Contech Slotted Drain is a versatile and cost effective solution for surface water removal on many sites.

Wide Range of Applications



Example of an overland sheet flow.



About 3,900 feet of 12-inch HEL-COR®, 16-gage Slotted Drain in the Indianapolis, Indiana, area allows water to drain between the lane barrier and the shoulder. Replacing curbs and drain basins with continuous lengths of Slotted Drain opens up an obstruction-free and single grade roadside that greatly enhances the effectiveness of the shoulder to improve the safety on the highway (photo above).



Slotted Drain is widely used in parking areas and driveways, where its ability to provide efficient drainage, without the need for hazardous dips in pavement, is a safety asset.

Grate Inlet Hydraulic FHWA Test

Slotted Drain can be used to intercept runoff in any one of the following ways:

1. Installed in a typical curb-and-gutter as a slot-on-grade to intercept flow from streets and highways.

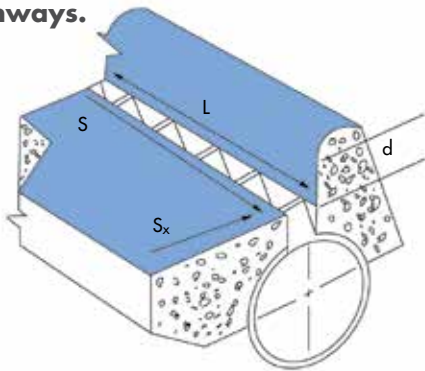

For any given flow into an inlet, Q , cross slope, S_x , and longitudinal gutter slope, S , the required Slotted Drain length can be determined from the nomograph (Figure A) on Page 7.

It is common practice in curb-and-gutter drainage design to carry over up to 35% of the total flow at an upstream inlet, Q , to other inlets downstream. See Figure B on Page 7 for the carryover efficiency curve. Q_i is the capacity of the grate to intercept and discharge the runoff into the CSP below it. Any bypass flow, Q_b , will flow overtop of the inlet and continue down the gutter to be intercepted by another slot-on-grade or a slot-in-sag. Because of the larger diameter pipe typically used, i.e., 15" and 18", Contech Slotted Drain has a much larger system capacity than the competitors' systems.

2. Installed in a typical curb-and-gutter at a sag - Slot-in-sag

Installed in a typical curb-and-gutter at a sag or low point in a grade to accommodate carryover from preceding slots on a grade and to intercept surface runoff sloped to the gutter.

Installed in wide, flat areas to intercept overland or sheet flow (as on a parking lot).

When Slotted Drain is installed in a sag or at a low point in grade, the length of the slot is calculated from the formula:

$$L_r = \frac{1.4Q}{\sqrt{d}}$$

Normally a safety factor of two is used in a sag. $L_s = 2 \times L_r$.

3. Overland sheet flow

Slotted Drain is used effectively to intercept runoff from wide, flat areas such as parking lots, highway medians—even tennis courts and airport taxiways. In these installations, the drain is placed transverse to the direction of flow, so that the open slot acts as a weir intercepting all of the flow uniformly along the entire length of the drain. The water is not collected and channeled against a berm (curb), as required by slot-on-grade installations.

Slotted Drain has been tested for overland flow (sheet flow). These results are published in Report No. FHWA-RD-79-106 by the Federal Highway Administration.

The test system was designed to supply at least 0.025 cfs per foot, which corresponds to a rainstorm of 1.5 inches per hour over a 72-foot-wide roadway (six lanes).

At the design discharge of 0.025 cfs per foot, the total flow fell through the slot as a weir flow. The tests included flows up to 0.040 cfs per foot of slot.

Slopes ranged from a longitudinal slope of 9% and a Z of 16, to a longitudinal slope of 0.5% and a Z of 48.

The water ranged in depth from 0.38 inches to 0.56 inches. Velocity ranged from 1.263 ft/sec to 0.857 ft/sec.

Even at the maximum discharge of 0.04 cfs per foot and maximum slopes, nearly all the flow passed through the slot. Only some water hitting the spacer plates and splashing over was not intercepted.

Using:

$$Q = CIA, \text{ then } A = \frac{Q}{CI}$$

Where:

Q given as 0.04 ft³/sec/ft of slotted drain

$C = 0.80$ to 0.95 for asphalt pavement

After the engineer selects C and I (ft/sec), A can be calculated. Since Q is per foot of slot, A is ft²/ft of slot. Since the units for A can be reduced to feet, the value of A is also the distance parallel to the flow intercepted by one foot of slot.

Example:

$C = 0.85$

$I = 10 \text{ in./hr}$ or 0.0002315 ft/sec

$$A = \frac{0.04 \text{ ft}^3/\text{sec}/\text{ft}}{0.85 \times 0.0002315 \text{ ft/sec}}$$

$A = 203.3 \text{ ft}^2/\text{ft}$

Therefore, at the selected C and I , one foot of slot will intercept flow from 203.3 linear feet upstream of the slot.

Figure A: Nomograph—Slotted Drain on Grade in Curb-and-Gutter

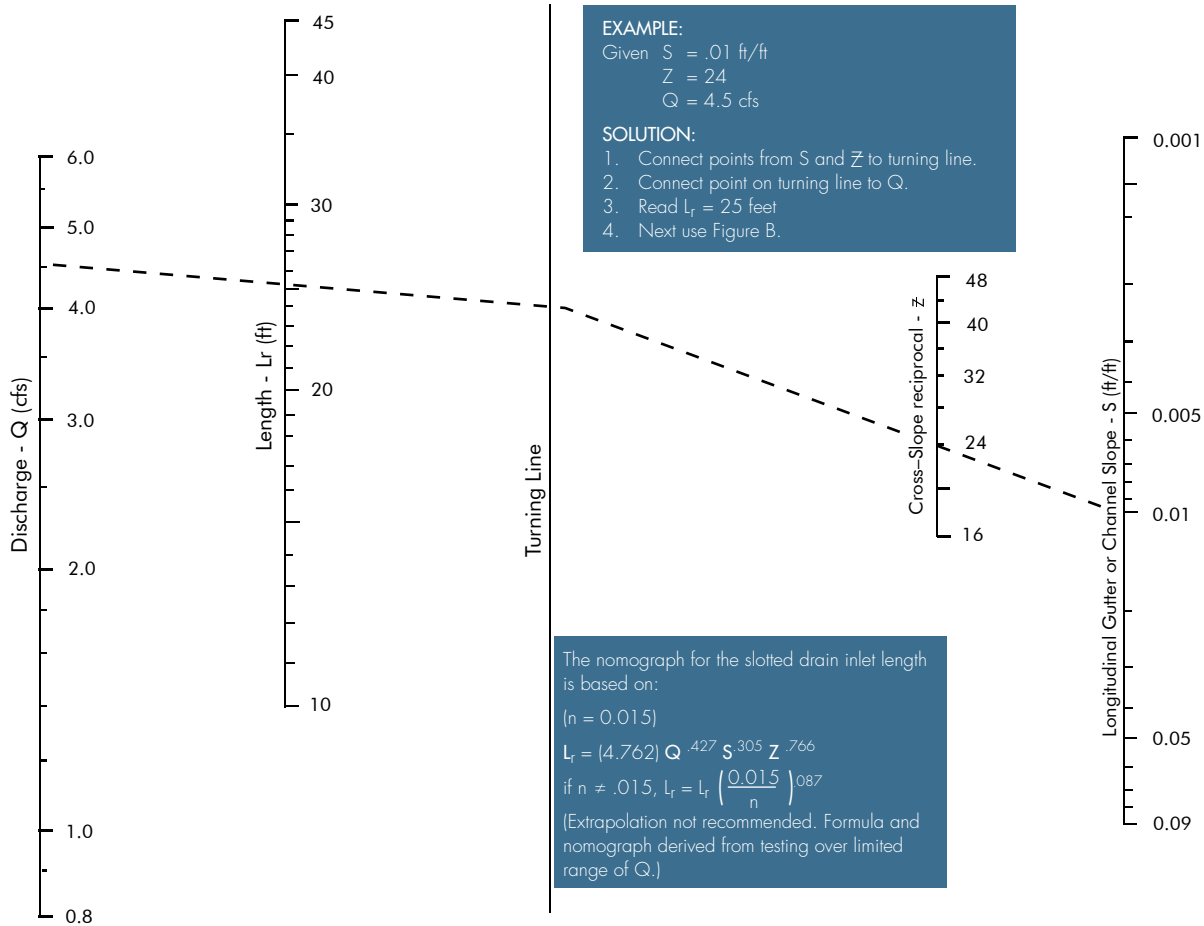
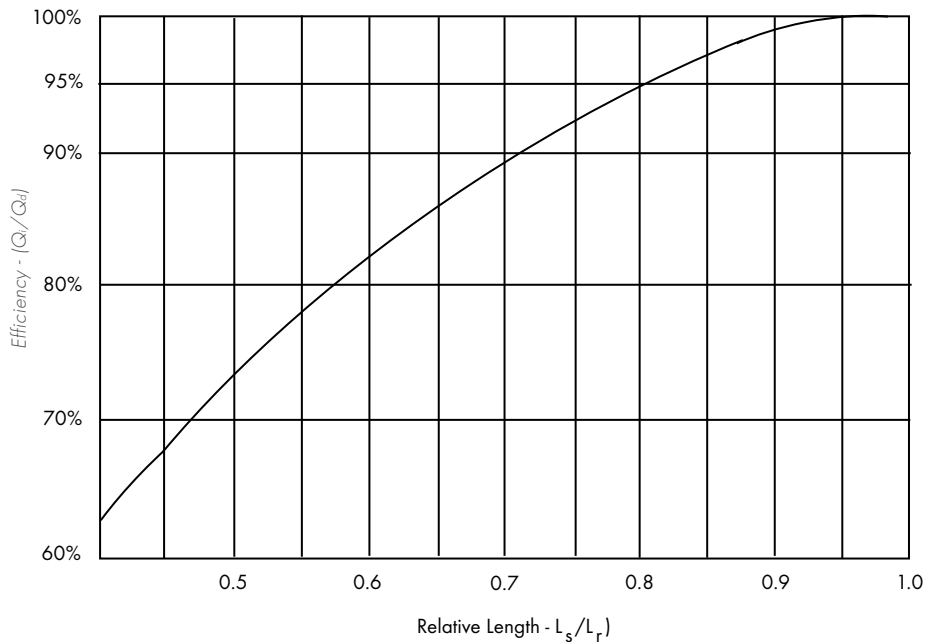

Figure B: Slotted Drain Carryover Efficiency



Definitions

- S — Longitudinal gutter or channel slope, ft/ft
- S_x — Transverse slope, ft/ft
- Z — Transverse slope reciprocal
- d — Depth of flow over the slot, ft
- L_r — Length of slot required for total interception, ft
- L_s — Selected length of slot, ft
- Q — Total flow into inlet, cfs
- Q_i — Intercepted flow at inlet, cfs
- Q_b — Bypass flow, cfs
- C — Runoff coefficient
- I — Rainfall intensity, ft/sec
- A — Area drained, ft²/ft

Example: Solution from Figure A is $L_r = 25$ feet. If a standard 20-foot length is used, relative length ratio $L_s/L_r = 20 \text{ ft} / 25 \text{ ft} = 0.8$. From Figure B with a relative length ratio of 0.8, the efficiency is 95%; therefore, the intercepted flow at the inlet, $Q_i = 0.94 \times 4.5 \text{ cfs} = 4.23 \text{ cfs}$. This flow is intercepted by the 20-foot length, and the remaining bypass flow runs down the gutter to be intercepted by the next slot. The bypass flow of $0.06 \times 4.5 \text{ cfs} = 0.27 \text{ cfs}$ must be added to the flow downstream of the slot in this example to be intercepted by another slot or drainage structure (fixture), such as a slot-in-sag inlet.

Installation

Contech Slotted Drain's primary advantages are its economical design and ease of installation. Unlike typical parking lots that require grades to be sloped in four directions for each storm collection grate, a parking lot with slotted drain requires only one transverse and one longitudinal slope for the entire drainage area. That translates to a lower-cost installation for the contractor and owner; and less stake-out for the engineer. Because of slotted drain's efficiency in removing surface water, fewer collectors and laterals under the roadway are needed.

When properly installed, Slotted Drain provides a better-looking, more efficient drainage system at a lower cost. Photographs illustrate the basic steps for installing slotted drain as a curb inlet. The procedure is basically the same in other applications.

Experience has shown the best method for installing Slotted Drain is to place it in a contoured trench, level it to grade, backfill with high slump concrete, then pave with the desired surfacing material. The pipe must be placed so the slanted spacer plates are facing upstream, leaning against the direction of surface flow.

In long runs, construction joints should be placed perpendicular to the pipe runs.

Modified HUGGER Bands or the closure plate jointing system is used to join adjacent pipes.

Your Contech Sales Engineer can discuss various installation techniques with you.

Leveling to grade

Contractors have developed many methods for positioning Slotted Drain in the trench prior to the backfilling.

One popular method is to use positioning devices fastened through the slotted opening with a toggle bolt or similar device.

Another method involves leveling the pipe with granular material at selected points along the drain pipe. The remaining area is backfilled with high slump concrete.

Anchoring devices may be required to avoid flotation during the backfill process.

Grate extensions

Grate extensions are available up to a maximum height of 31".

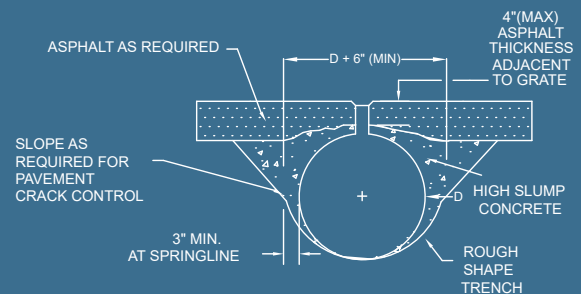
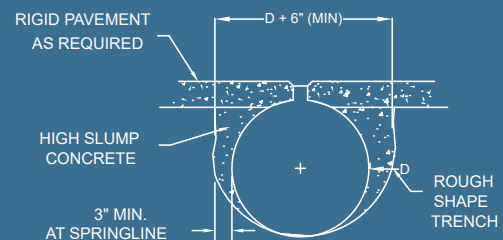

Recommended installation practices. Great style is as required. For installation aids, call your local Contech Sales Engineer

High slump concrete

After the Slotted Drain has been leveled to grade, it is important that a high slump concrete or lean grout (minimum 750 psi compressive strength) be used as backfill. The high slump concrete helps ensure a uniform foundation and side support and transfers the live load to the surrounding earth. In non-live load areas, A-1-a AASHTO M145 backfill or cement stabilized sand is sufficient.

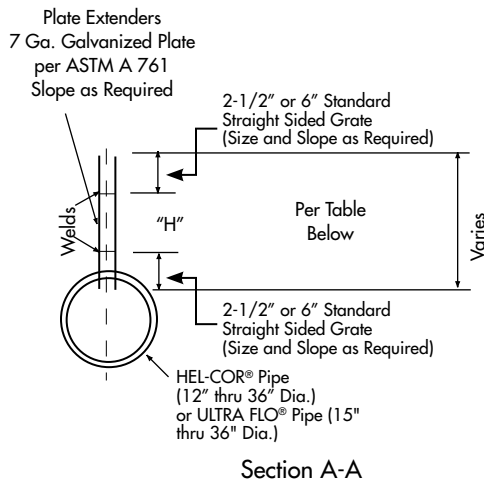
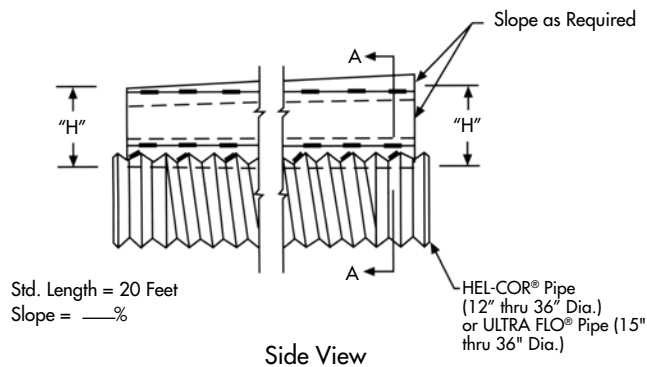

Loading Condition	Maximum Separation Height - "H"
<H10 * Granular Backfill	8"
H20/H25 * 750 PSI Concrete	19"
Airport ** 1000 PSI Concrete	12"

* 125 PSI Tire Pressure

** 195 PSI Tire Pressure

Surfacing

Once the Slotted Drain is backfilled with high slump concrete, cover the slotted opening before surfacing and leave it covered until the paving operation is complete. Duct tape, metal strips or lumber can be used to cover the slot.



Slotted Drain Specification

1.0 General

- 1.1 This specification covers Slotted Drain used for removal of water as shown on the plans.
- 1.2 The corrugated steel pipe used in the Slotted Drain shall meet the requirements of AASHTO M36/ASTM A 760. The CSP shall be made of ALUMINIZED STEEL Type 2 (AASHTO M274). The diameter and gage shall be as shown on the plans.

2. Connections

- 2.1 The CSP shall have a minimum of two rerolled annular ends.
- 2.2 The Slotted Drain bands shall be modified HUGGER Bands to secure the pipe and prevent infiltration of backfill.
- 2.3 When the Slotted Drain is banded together, the adjacent grates shall have a maximum 3-inch gap.

3. Grates

- 3.1 The grates shall be manufactured from ASTM A 1011, Grade 36 or ASTM A 36 steel. The spacers and side plates shall be $\frac{3}{16}$ -inch material ± 0.008 inches. The plate extenders are minimum 7 gage and made from ASTM A 761 or the above materials.
- 3.2 The spacer plates shall be on 6-inch centers and welded on both sides to each bearing plate (sides) with four $1\frac{1}{4}$ -inch-long $\frac{3}{16}$ -inch fillet welds on each side of the bearing plate.
- 3.3 The engineer may call for tensile strength test on the grate if the grate is not in compliance with 3.1 and 3.2. If tensile strength tests are called for, minimum results for an in-place spacer plate pulled perpendicular to the bearing plate shall be:

T = 12,000 pounds for 2 $\frac{1}{2}$ -inch grate

T = 15,000 pounds for 6-inch grate

- 3.4 The grates shall be trapezoidal with a $1\frac{3}{4}$ -inch opening in the top and 30° slanted spacer plates unless shown otherwise on the plans. The grate shall be 2 $\frac{1}{2}$ inches high or 6 inches high as shown on the plans.

Note

For Slotted Drain installations with other than 2 $\frac{1}{2}$ " or 6" standard grate, i.e. variable height and for all special loading conditions, contact your Contech Sales Engineer.

4. Galvanizing

- 4.1 The grate shall be galvanized in accordance with ASTM A 123 except with a 2-ounce galvanized coating.

5. Grate Attached to CSP

- 5.1 For standard highway loading, the grate shall be fillet welded a minimum 1-inch long to the CSP on each side of the grate or at every corrugation for loads which exceed highway vehicles.

6. Tolerances—Finished Slotted Drain Grates—20-foot Lengths

- 6.1 Vertical bow is $\pm \frac{3}{8}$ inch.
- 6.2 Horizontal bow is $\pm \frac{5}{8}$ inch.
- 6.3 Twist is $\pm \frac{1}{2}$ inch.



Connecticut I-84 Hartford/Boston Corridor.



Slotted Drain is often used at airports where large flat areas are necessary to accommodate airplanes moving in and out of terminal areas. The municipal airport at Colorado Springs, Colorado, solved water ponding problems adjacent to the airport aprons with Slotted Drain. It intercepts sheet flow before ponding begins. For airport loading (tire pressure in excess of 125 psi), contact your Contech Sales Engineer.



Designers and engineers installing walkways and promenades around sports stadiums, civic centers, shopping malls, parks and other pedestrian-traveled surfaces have used Slotted Drain as an integral part of the landscape architecture.

CONTECH[®]

ENGINEERED SOLUTIONS
A QUIKRETE[®] COMPANY

Contech[®] Engineered Solutions provides innovative, cost-effective site solutions to engineers, contractors and developers on projects across North America. Our portfolio includes bridges, drainage, erosion control, retaining wall, sanitary sewer and stormwater management products.



STORMWATER
SOLUTIONS



PIPE
SOLUTIONS



STRUCTURE
SOLUTIONS

For more information call:

Corporate Office - Ohio (Cincinnati)	513-645-7000
California (Roseville)	800-548-4667
Colorado (Denver)	720-587-2700
Florida (Orlando)	321-348-3520
Maine (Scarborough)	207-885-9830
Maryland (Baltimore)	410-740-8490
Oregon (Portland)	503-258-3180
Texas (Dallas)	972-590-2000

www.ContechES.com | 800-338-1122



© 2025 Contech Engineered Solutions LLC, a QUIKRETE Company
800-338-1122

www.ContechES.com

All Rights Reserved. Printed in the USA.

NOTHING IN THIS CATALOG SHOULD BE CONSTRUED AS A WARRANTY. APPLICATIONS SUGGESTED HEREIN ARE DESCRIBED ONLY TO HELP READERS MAKE THEIR OWN EVALUATIONS AND DECISIONS, AND ARE NEITHER GUARANTEES NOR WARRANTIES OF SUITABILITY FOR ANY APPLICATION. CONTECH MAKES NO WARRANTY WHATSOEVER, EXPRESS OR IMPLIED, RELATED TO THE APPLICATIONS, MATERIALS, COATINGS, OR PRODUCTS DISCUSSED HEREIN. ALL IMPLIED WARRANTIES OF MERCHANTABILITY AND ALL IMPLIED WARRANTIES OF FITNESS FOR ANY PARTICULAR PURPOSE ARE DISCLAIMED BY CONTECH. SEE CONTECH'S CONDITIONS OF SALE (AVAILABLE AT WWW.CONTECHES.COM/COS) FOR MORE INFORMATION.

