



Corrugated Steel Conveyor Covers

Economical, Durable Conveyor Protection

Contech Corrugated Steel Conveyor Covers provide economical and durable conveyor protection. These lightweight, easy-to-assemble structures have a long history of proven performance in a variety of industrial, mining and similar applications. High-strength, pre-shaped components allow quick and low-cost installation, while zinc protective coatings prolong service life and reduce maintenance.

Contech steel conveyor covers and supports are dimensioned as 4'x8' wide units, each using a 2 2/3" x 1/2" corrugated steel sheet. Cover sheets are available in either 16- or 18-gage steel, and all components are pre-galvanized. Overall covering widths may be selected to range from 30 inches to 72 inches.

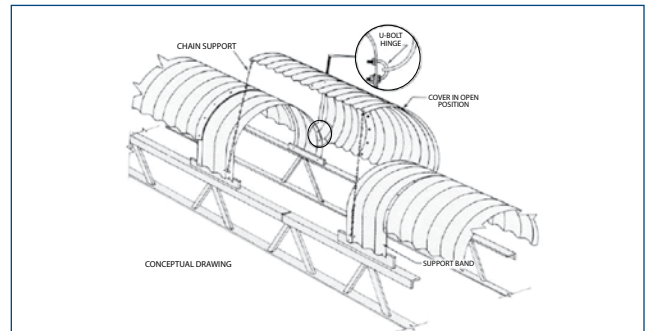
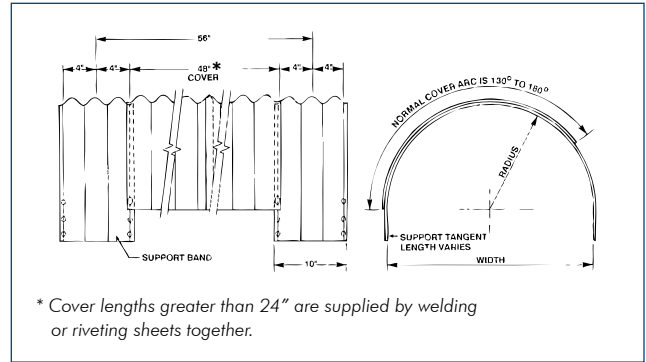

Proven Solutions

Contech's experience and expertise in solving industrial conduit problems utilizing corrugated steel structures benefits you when selecting and specifying conveyor covers. Your Contech Sales Representative can assist you in determining the appropriate cover size and other components needed for your particular application.

Field assembly is fast and easy with self-drilling, self-tapping screws for the attachments.

With Contech's 10-inch (8-inch net) wide support bands, (12-, 14- or 16-gage), idler interference is not a problem from a greasing standpoint.

The excellent corrosion resistance of pre-galvanized steel covers and support bands produce long-term economy, as evidenced by over 40 years of successful field applications. Zinc-coated sheets and support bands meet all of the requirements of AASHTO M-218 Specification.

For special applications, aluminum conveyor covers are also available.

Get Social With Us!



800-338-1122
www.ContechES.com

©2015 Contech Engineered Solutions LLC